

MedeaWiz® Hydra®

Model H-9X28D Input / Output Expander for Sprite®

User Manual

Firmware version 3

Manual version 3.01



Please go to www.MedeaWiz.com for latest version.

Also refer to V 4.00 and later versions of the manual for more information.

Table of Contents

Introduction	2
Hydra™ Quick Start Guide.....	3
Program Function Modes	4
Setting Mode by Jumper Wires.....	19
Setting Mode by Push Button	21
Wiring a Pushbutton to the Input Port	25
Wiring Connections to the Output Port.....	26
Wiring Connections to Port 2.....	28
Port 2 Motion Sensor Wiring	28
Setting Re-Trigger Delay	29
Matrix and Keypad Button Wiring	30
DMX Control.....	33
Wiring Connections to the DMX Port	34
Setting DMX Address by Jumper Wires	35
Setting DMX Mode and Address by the Set Push Button	37
Restore Default Settings	38
Firmware Upgrade / User Programming	38
PLC Interfacing	39
Schematics of I/O on the 9X28D Hydra™ circuit board	40
Trouble FAQ	44
Firmware Revisions	45
Support	46
Custom Orders	46

Introduction

The MedeaWiz® Hydra® is an Input and Output expander for the MedeaWiz® Sprite® HD video player. It adds multiple trigger inputs and outputs, a motion sensor input and DMX512 control input. The Hydra connects to the Sprite serial port with the included 3.5mm 4 pole cable.

Many customers will use the factory set default Mode 1. It has 9 push button inputs plus a motion sensor input and 8 outputs. The first 8 inputs will play files named 001 – 008. The motion sensor input will also play file 001. The inputs are No Interrupt. This means that once a file is triggered it will play to the end. Any other triggers during this time are ignored. The corresponding output 1 – 8 will be active while the file is playing. Input 9 will interrupt and force the Sprite back to the looping file named 000.

Key Features

Many pre-programmed and user selectable modes of operation including:

9 trigger inputs with 8 sinking outputs

5 x 5 matrix for up to 25 trigger inputs

3 x 4 keypad for up to 99 triggered files

Delayed trigger options

DMX512 control for the Sprite up to 200 files - plus 8 individual sinking outputs

Can control 2 Sprites in some Modes

PIR motion sensor input with user selectable re-trigger delay time from 1 to 999 seconds

Random triggers

Incremented step next / previous triggers

Trigger alternate looping files

Set alternate looping files paired with alternate trigger files

Queued triggers

PIC18F processor can be custom programmed by us or you for specific needs.

The Hydra® is energy efficient using 5 Volt DC power at an average of 15 mA, and is powered from the Sprite® video player.

The Hydra is FCC, CE and RoHS certified.

Hydra® Quick Start Guide

Connect the Hydra Port 1 to the Sprite I/O port using the included 3.5mm 4 pole cable. The cable provides power from the Sprite as well as 2-way serial communications.

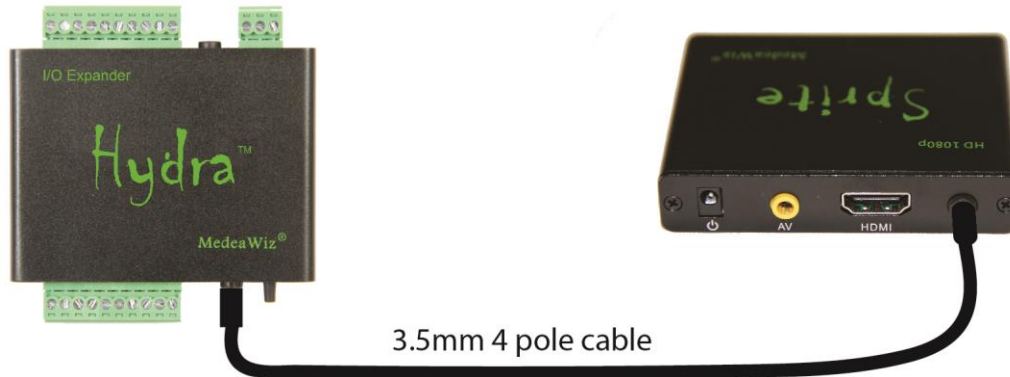

Set up your Sprite

Enter the Setup menu of the Sprite by pressing the SETUP button on the remote control.
 Set the Play Mode to Video Control Mode for video files, OR Audio Control Mode for audio files.
 Set the Control Mode to Serial Control
 Set the Baud Rate to 9600
 Set the Address to Do not use addressing

Always have a looping file named 000 on your SD or USB memory:

The 000 looping file can be a black video file if no video is wanted until a trigger or command.
 The looping file can be a silent audio file named 000 if you are using Audio Control Mode.
 We suggest the looping file be at least 10 seconds long. Longer will help the SD card life.

Make sure you are using ZEROS and not the letter O in the file name. Do not put the files in a folder. Only put media files on the SD card or USB drive.

You can download HD test files at <http://www.highdefforum.com/high-definition-movies-video-clips/6537-official-hd-video-clip-list.html>

The Hydra factory default Mode 1

The basic Mode 1 has 9 push button trigger inputs and 8 sinking outputs, No Interrupt.
 Optionally you can use a motion sensor on Port 2. When a file is triggered it will play to the end, even if other inputs are triggered. If this is the Mode you need, skip to page 25 for wiring your push buttons and you're done.

Learn more about the different Modes of operation available from the table on page 4 and the detailed descriptions that follow it.

Program Function Modes

There are several different user-selectable Modes that the Hydra can operate in. Select the Mode number from the table below for your application.

- There are presently 2 ways to program the operation Mode:
- 1) Use wire jumpers from ground to specified inputs. See page 19.
 - 2) Use the Set push button switch on the front panel. See page 21.

Hydra operation Modes. Detailed information on each Mode follows below this table.

Mode	Function
1	9 inputs + motion input with re-start delay, 8 outputs, no interrupt (Default Mode)
2	9 inputs + motion input with re-start delay, 8 outputs, with interrupt
3	9 inputs + motion, button press resets motion re-start delay, 8 outputs, no interrupt
4	9 inputs + motion, button press resets motion re-start delay, 8 outputs, w/ interrupt
5	9 inputs + motion input with re-start delay, 8 outputs, delayed trigger
6	9 in + motion input w/ re-start delay, 8 out, motion only triggers if 000, w/ interrupt
11	Next / Previous file, no interrupt, 9 input, motion input with re-start delay
12	Next / Previous file, with interrupt, 9 input, motion input with re-start delay
13	Next / Previous file, Delayed trigger, 9 input, motion input with re-start delay
15	Random triggers, input 1 and motion input with re-start delay, no interrupt
16	Random triggers, input 1 and motion input with re-start delay, with interrupt
17	Random triggers, input 1 and motion input with re-start delay, with delayed trigger
21	9 inputs, 8 outputs, 2 Sprite, no interrupt
22	9 inputs, 8 outputs, 2 Sprite, with interrupt
23	2 Sprite, 4 inputs each, 8 outputs, no interrupt
24	2 Sprite, 4 inputs each, 8 outputs, with interrupt
31	3 x 4 matrix, 12 button keypad, plays 12 files, no interrupt
32	3 x 4 matrix, 12 button keypad, plays 12 files, with interrupt
33	3 x 4 matrix, 12 button keypad, plays 99 files, no interrupt
34	3 x 4 matrix, 12 button keypad, plays 99 files, with interrupt
37	3 x 4 matrix, 12 button keypad, plays 99 files, no interrupt – Storm brand keypad
38	3 x 4 matrix, 12 button keypad, plays 99 files, with interrupt – Storm brand keypad
41	4 x 4 matrix, 16 button keypad, plays up to 16 files, no interrupt
42	4 x 4 matrix, 16 button keypad, plays up to 16 files, with interrupt

51	5 x 5 matrix, 25 button keypad, plays up to 25 files, no interrupt
52	5 x 5 matrix, 25 button keypad, plays up to 25 files, with interrupt
61	Play alternate looping files, 9 inputs – 8 outputs, w/ interrupt
63	Play alt. loop files with alt. paired triggered files, motion input w/ delay, no interrupt*
64	Play alt. loop files with alt. paired triggered files, motion input w/ delay, with interrupts
65	Play alt. loop files with alt. paired triggered files, motion input w/ delay, delayed trigger
71	9 inputs + motion (with re-start delay), 8 outputs pulse Low after file ends, no interrupt
72	9 inputs + motion (with re-start delay), 8 outputs pulse Low after file ends, w/ interrupt
73	2 Sprite, 4 inputs each, 8 outs pulse Low at EOF, re-start delay on input 1, no interrupt
74	2 Sprite, 4 inputs each, 8 outs pulse Low at EOF, re-start delay on input 1, with interrupt
81	1 Sprite, 9 in, 8 out, files queued, play in the order of inputs triggered, no interrupt
82	1 Sprite, 9 in, 8 out, files queued, play in the order of inputs triggered, delayed trigger
91	DMX input, 1 channel, play up to 200 files, safe mode, no control commands
92	DMX input, 1 channel, play up to 200 files, full mode, all commands active
95	DMX in, 9 channels, up to 200 files plus 8 individually controlled outputs, safe mode
96	DMX in, 9 channels, up to 200 files plus 8 individually controlled outputs, full mode
99	Flash LED to show firmware version installed

(Mode detailed explanations on next page.)

Modes Details

Mode 1 – Factory Set Default Mode

9 inputs + motion input with re-start delay, 8 outputs, no interrupt

Mode 1 controls one Sprite on Port 1.

It has 9 trigger inputs plus an optional motion sensor input on Port 2.

The sensor trigger on PORT 2 has a user selectable delay time to wait before a new trigger.

There are 8 sinking outputs.

When power is applied the file named 000 will loop circular continuously until a trigger event.

Inputs 1 to 9 will trigger when grounded / connected to input 0

A trigger (ground) on input 1 to 8 will cause the corresponding file named 001 to 008 to play.

Mode 1 is No Interrupt

While a file 1 to 8 is playing, any new trigger on input 1 to 8 or Port 2 will be ignored.

While the file 1 to 8 is playing, the corresponding sinking output number will be active.

Port 2 is set for a motion sensor input and will trigger on a +3 to +5 Volt input. Plays file 001.

Re-trigger delay on Port 2 is preset to 30 seconds but may be changed from 1 to 999 seconds.

A push button or other device can be used instead of a motion sensor on Port 2. See page 28.

Input 9 will interrupt other files, return to the 000 looping file and turn off sinking outputs.

Mode 1 can be used with from 1 up to 9 pushbuttons, contacts or a low voltage controller.

You can use an optional motion sensor or other trigger on Port 2.

Or you can use the motion sensor or other trigger on Port 2 alone.

The user selectable re-trigger delay on Port 2 can be used in various ways.

In a kiosk or special effect, you may want some quiet time between motion triggers.

You can also connect a jumper wire to force a trigger at intervals set by the delay time.

Find more information about Port 2 on page 28.

Mode 2

9 inputs + motion input with re-start delay, 8 outputs, with interrupt

Mode 2 is exactly the same as Mode 1, except With Interrupts.

Any file playing may be interrupted to start a new file when a new input trigger occurs.

There is a brief delay before a new trigger is allowed if a prior triggered file just began.

Mode 3

9 inputs + motion, button press resets motion re-start delay, 8 outputs, no interrupt

Mode 3 is like Mode 1 except any button press will reset the Port 2 motion sensor re-trigger

delay time. The re-trigger delay timer will start counting when the button is pressed. It is not

possible to trigger Port 2 until the timer count ends. Any new button press during this time will

reset the delay timer again. The re-trigger delay time can be set from 1 to 999 seconds.

Mode 3 is No Interrupt

While a file 1 to 8 is playing, any new trigger on input 1 to 8 or Port 2 will be ignored.

Mode 4

9 inputs + motion, button press resets motion re-start delay, 8 outputs, with interrupt

Mode 4 is exactly the same as Mode 3 except With Interrupts.

Any file playing may be interrupted to start a new file when a new input trigger occurs.

There is a brief delay before a new trigger is allowed if a prior triggered file just began.

Mode 5

9 inputs + motion input with re-start delay, 8 outputs, delayed trigger

Mode 5 controls one Sprite on Port 1.

It has 9 trigger inputs plus an optional motion sensor input on Port 2.

It has 8 sinking outputs.

When power is applied the file named 000 will loop circular continuously until a trigger event.

Inputs 1 to 9 will trigger when grounded / connected to input 0.

A trigger (ground) on input 1 to 8 will cause the corresponding file named 001 to 008 to play.

Mode 5 is No Interrupt

While a file 1 to 8 is playing, any new trigger on input 1 to 8 will be ignored.

While the file 1 to 8 is playing, the corresponding sinking output will be active.

Port 2 is set for a motion sensor input and will trigger on a +3 to +5 Volt input. Plays file 001.

A trigger on inputs 1 to 8 or Port 2 will cause the file to begin playing, just as file 000 ends.

The trigger will delay until file 000 is finished.

Read FAQ about Delayed Trigger at end of manual.

Mode 5 is No Interrupt

A new input trigger will be ignored while a prior triggered file is playing.

Input 9 will interrupt other files, return to the 000 looping file and turn off sinking outputs.

The user selectable re-trigger delay on Port 2 can be used in various ways.

In a kiosk or special effect, you may want some quiet time between motion triggers.

You can also connect a jumper wire to force a trigger at intervals set by the delay time.

Find more information about Port 2 on page 28.

Mode 6

9 in + motion input w/re-start delay, 8 out, motion only triggers if 000 playing, w/ interrupt

Mode 6 controls one Sprite on Port 1.

It has 9 trigger inputs plus a motion sensor input on Port 2.

Sensor trigger on PORT 2 has a user selectable delay time to wait before a new trigger.

It has 8 sinking outputs.

When power is applied the file named 000 will loop circular continuously until a trigger event.

Inputs 1 to 9 will trigger when grounded / connected to input 0

A trigger (ground) on input 1 to 8 will cause the corresponding file named 001 to 008 to play.

Mode 6 is With Interrupt

While a file 1 to 8 is playing, any new trigger on input 1 to 8 will begin playing.

While the file 1 to 8 is playing, the corresponding sinking output will be active. Port 2 is set for a motion sensor input and will trigger on a +3 to +5 Volt input. Plays file 001. Port 2 will only trigger if the looping file 000 is playing. It will not interrupt files 001 – 008. Inputs 1 to 8 will interrupt the Port 2 triggered file 001. Re-trigger delay on Port 2 is preset to 30 seconds but may be changed from 1 to 999 seconds. Input 9 will interrupt any file, return to the 000 looping file and turn off sinking outputs.

The user selectable re-trigger delay on Port 2 can be used in various ways. In a kiosk or special effect, you may want some quiet time between motion triggers. You can also connect a jumper wire to force a trigger at intervals set by the delay time. Find more information about Port 2 on page 28.

Mode 11

Next / Previous file, no interrupt, 9 input, motion input with re-start delay

Mode 11 controls one Sprite on Port 1.

It has 9 trigger inputs plus an optional motion sensor input on Port 2.

Sensor trigger on PORT 2 has a user selectable delay time to wait before a new trigger.

There are no sinking outputs programmed.

When power is applied the file named 000 will loop circular continuously until a trigger event.

Inputs 1 to 9 will trigger when grounded / connected to input 0.

A trigger on input 1 will play the next file on the SD or USB, circular, excluding file 000.

A trigger on Port 2 will play the next file on the SD or USB, circular, excluding file 000.

A trigger on input 2 will play the previous file on the SD or USB, circular, excluding file 000.

You may use files named 001 up to 200 on the SD or USB drive. Do not skip numbers.

A trigger on inputs 3 to 8 will play files 001 to 006. This will not change the step file count.

Mode 11 is No Interrupt

A new input trigger will be ignored while a prior triggered file is playing.

Re-trigger delay on Port 2 is preset to 30 seconds but may be changed from 1 to 999 seconds.

Input 9 will interrupt other files, return to the 000 loop file and reset the step file count to 001.

The user selectable re-trigger delay on Port 2 can be used in various ways.

In a kiosk or special effect, you may want some quiet time between motion triggers.

You can also connect a jumper wire to force a trigger at intervals set by the delay time.

Find more information about Port 2 on page 28.

Mode 12

Next / Previous file, with interrupt, 9 input, motion input with re-start delay

Mode 12 is exactly the same as Mode 11, except With Interrupts.

Any file playing may be interrupted to start a new file when a new input trigger occurs.

There is a brief delay before a new trigger is allowed if a prior triggered file just began.

Mode 13

Delayed trigger step on Input 1 and motion input. Motion has re-start delay.

Mode 13 controls one Sprite on Port 1.

It is similar to Mode 11, but with delayed triggering.

Trigger will only occur at the end of the looping file 000.

Read FAQ about Delayed Trigger at end of manual.

It has 9 trigger inputs plus an optional motion sensor input on Port 2.

Sensor trigger on PORT 2 has a user selectable delay time to wait before a new trigger.

There are no sinking outputs programmed.

When power is applied the file named 000 will loop circular continuously until a trigger event.

Inputs 1 to 9 will trigger when grounded / connected to input 0.

Any trigger below will delay until the looping file 000 ends.

A trigger on input 1 will play the next file on the SD or USB, circular, excluding file 000.

A trigger on Port 2 will play the next file on the SD or USB, circular, excluding file 000.

A trigger on input 2 will play the previous file on the SD or USB, circular, excluding file 000.

A trigger on inputs 3 to 8 will play files 001 to 006.

Mode 13 is No Interrupt

A new input trigger will be ignored while a prior triggered file is playing.

After a triggered file plays, the 000 loop file will play and is ready for a new delayed trigger.

Re-trigger delay on Port 2 is preset to 30 seconds but may be changed from 1 to 999 seconds.

Input 9 will interrupt other files and return to the 000 looping file.

Mode 15

Random file triggers on input 1 and motion input (with re-start delay), no interrupt

Mode 15 controls one Sprite on Port 1.

It has 1 trigger input plus an optional motion sensor input on Port 2.

Sensor trigger on PORT 2 has a user selectable delay time to wait before a new trigger.

There are no sinking outputs programmed.

When power is applied the file named 000 will loop circular continuously until a trigger event.

Input 1 will trigger when grounded / connected to input 0

Port 2 is set for a motion sensor input and will trigger on a +3 to +5 Volt input.

A trigger on input 1 or Port 2 will play a randomly selected file .

You may use files named 001 up to 200 on the SD or USB drive. Do not skip numbers.

Mode 15 is No Interrupt

A new input trigger will be ignored while a prior triggered file is playing.

Re-trigger delay on Port 2 is preset to 30 seconds but may be changed from 1 to 999 seconds.

The user selectable re-trigger delay on Port 2 can be used in various ways.

In a kiosk or special effect, you may want some quiet time between motion triggers.

You can also connect a jumper wire to force a trigger at intervals set by the delay time.

Find more information about Port 2 on page 28.

Mode 16**Random file triggers on input 1 and motion input (with re-start delay), with interrupt**

Mode 16 is exactly the same as Mode 15, except With Interrupts.

Any file playing may be interrupted to start a new file when a new input trigger occurs.

There is a brief delay before a new trigger is allowed if a prior triggered file just began.

Mode 17**Random file triggers on input 1 and motion input (with re-start delay), with delayed trigger**

Mode 17 is the same as Mode 15, but with a delayed trigger.

A trigger on input 1 or Port 2 will cause a random file to begin playing, just as file 000 ends.

The trigger will delay until file 000 is finished.

Read FAQ about Delayed Trigger at end of manual.

Mode 17 is No Interrupt

A new input trigger will be ignored while a prior triggered file is playing.

After a triggered file plays, the 000 loop file will play and is ready for a new delayed trigger.

Mode 21**9 inputs, 8 outputs, 2 Sprite, no interrupt**

Mode 21 controls two Sprites, one on Port 1 and one on Port 2.

Both Sprites will trigger and play the same file numbers.

It has 9 trigger inputs.

It has 8 sinking outputs.

When power is applied the file named 000 will loop circular continuously until a trigger event.

A trigger (ground) on input 1 to 8 will cause the corresponding file named 001 to 008 to play.

Mode 21 is No Interrupt

While a file 1 to 8 is playing on Port 1, any new trigger on input 1 to 8 will be ignored.

While the file 1 to 8 is playing, the corresponding sinking output will be active.

Input 9 will interrupt other files, return to the 000 looping file and turn off sinking outputs.

The Sprite on Port 1 is the Master.

The Master dictates when a new trigger is allowed, after the current triggered file ends.

Mode 22**9 inputs, 8 outputs, 2 Sprite, with interrupt**

Mode 22 is exactly the same as Mode 21, except With Interrupts.

Any file playing may be interrupted to start a new file when a new input trigger occurs.

There is a brief delay before a new trigger is allowed if a prior triggered file just began.

Mode 23**2 Sprite, 4 inputs each, 8 outputs, no interrupt**

Mode 23 controls two Sprites, one on Port 1 and one on Port 2.

It has 9 trigger inputs.

It has 8 sinking outputs.

When power is applied the file named 000 will loop circular continuously until a trigger event.

Inputs 1 to 9 will trigger when grounded / connected to input 0

Inputs 1 to 4 will play files named 001 to 004 on the Sprite on Port 1.

Inputs 5 to 8 will play files named 001 to 004 on the Sprite on Port 2.

Mode 23 is No Interrupt

While a file 1 to 4 is playing on Port 1, any new trigger on inputs 1 to 8 will be ignored.

While a file 5 to 8 is playing on Port 2, any new trigger on inputs 1 to 8 will be ignored.

While the file is playing, the sinking output will be active that corresponds to the input number.

Input 9 will interrupt other files, return to the 000 looping file and turns off the outputs.

Mode 24

2 Sprite, 4 inputs each, 8 outputs, with interrupt

Mode 24 is exactly the same as Mode 23, except With Interrupts.

Any file playing may be interrupted to start a new file when a new input trigger occurs.

There is a brief delay before a new trigger is allowed if a prior triggered file just began.

Mode 31

3 x 4 matrix, 12 button keypad, plays 12 files, no interrupt

Mode 31 is for a 3 x 4 keypad or 12 individual push buttons or other triggers.

There are no sinking outputs programmed.

The 12 triggers will play files named 001 to 012.

Mode 31 is No Interrupt

A new input trigger will be ignored while a prior triggered file is playing.

Mode 32

3 x 4 matrix, 12 button keypad, plays 12 files, with interrupt

Mode 32 is exactly the same as Mode 31, except With Interrupts.

Any file playing may be interrupted to start a new file when a new input trigger occurs.

There is a brief delay before a new trigger is allowed if a prior triggered file just began.

Mode 33

3 x 4 matrix, 12 button keypad, plays 99 files, no interrupt

Mode 33 is for a 3 x 4 keypad or up to 12 individual push buttons or other triggers.

One or two buttons may be pressed followed by the # key button to play up to 99 files.

The 99 triggers will play files named 001 to 099.

The # key is used as the “enter” button to start the file number entered.

The * key is used as a “clear entry” button, if needed, prior to pressing the # key.

Mode 33 is No Interrupt

A new input trigger will be ignored while a prior triggered file is playing.

See page 32 for wiring the keypad / buttons.

See page 30 for the table of file numbers mapped to the buttons.

Mode 34

Mode 34 is exactly the same as Mode 33, except With Interrupts.

Any file playing may be interrupted to start a new file when a new input trigger occurs.

There is a brief delay before a new trigger is allowed if a prior triggered file just began.

Mode 37

Mode 37 is dedicated for a 3 x 4 Storm brand keypad.

The rows and columns are ordered differently, otherwise function is the same as Mode 33.

The Hydra circuit board has a provision for a ribbon cable to mate to the Storm keypad.

Mode 37 is No Interrupt

A new input trigger will be ignored while a prior triggered file is playing.

Mode 38

Mode 38 is dedicated for a 3 x 4 Storm brand keypad.

The rows and columns are ordered differently, otherwise function is the same as Mode 34.

The Hydra circuit board has a provision for a ribbon cable to mate to the Storm keypad.

Mode 38 is With Interrupts.

Any file playing may be interrupted to start a new file when a new input trigger occurs.

There is a brief delay before a new trigger is allowed if a prior triggered file just began.

Mode 41 – has a bug in FW v3– Use Mode 51

Mode 41 is for a 4 x 4 keypad or up to 16 individual push buttons or other triggers.

There are no sinking outputs programmed.

The 16 triggers will play files named 001 to 016.

Mode 41 is No Interrupt

A new input trigger will be ignored while a prior triggered file is playing.

Mode 42 – has a bug in FW v3– Use Mode 52

Mode 42 is exactly the same as Mode 41, except With Interrupts.

Any file playing may be interrupted to start a new file when a new input trigger occurs.

There is a brief delay before a new trigger is allowed if a prior triggered file just began.

Mode 51

Mode 51 is for a 5 x 5 keypad or up to 25 individual push buttons or other triggers.

There are no sinking outputs programmed.

The 25 triggers will play files named 001 to 025.

Mode 51 is No Interrupt

A new input trigger will be ignored while a prior triggered file is playing.

Mode 51 can also be used with a 5 x 4 keypad.

See page 32 for wiring the keypad / buttons.

See page 30 for the table of file numbers mapped to the buttons.

Mode 52

Mode 52 is exactly the same as Mode 51, except With Interrupts.
 Any file playing may be interrupted to start a new file when a new input trigger occurs.
 There is a brief delay before a new trigger is allowed if a prior triggered file just began.

Mode 61

Play alternate looping files

Mode 61 controls 1 Sprite on Port 1.
 It has 9 inputs.
 It has 8 sinking outputs.
 Triggers on inputs 1 – 8 will cause the files named 001 – 008 to become the looping file.
 While a looping file 1 to 8 is playing the corresponding sinking output is active.
 A trigger on input 9 will cause the file 000 to again be the looping file and all outputs off.
 Mode 61 is With Interrupts.
 Anytime an input 1 to 8 is triggered the new looping file number will start immediately.
 There is a brief delay before a new trigger is allowed if a prior triggered file just began.
 After a power cycle on the Sprite, the default file 000 will be looping.
 Mode 61 is useful to have alternate content looping, such as a menu board with breakfast, lunch and dinner loops, or daily event menus and etc.

Mode 63

Play alternate looping files with alternate paired triggered files, partial interrupts

Mode 63 controls 1 Sprite on Port 1.
 It has 9 inputs.
 It has 8 sinking outputs.
 It has 1 trigger input plus an optional motion sensor input on Port 2.
 Sensor trigger on PORT 2 has a user selectable delay time to wait before a new trigger.
 When power is applied the file named 000 will loop circular continuously until a trigger event.
 Input 1 to 9 will trigger when grounded / connected to input 0.
 Port 2 is set for a motion sensor input and will trigger on a +3 to +5 Volt input.

Inputs 2 to 8 will change the looping file, the output, and the triggered paired file as follows:

Input #	Will loop file	Output number on	Trigger input 1 or Port 2 plays file
2	002	2	003
3	004	3	005
4	006	4	007
5	008	5	009
6	010	6	011
7	012	7	013
8	014	8	015
9 (reset)	000	1	001

Mode 63 is No Interrupts on the triggered paired files.

Triggered files 1, 3, 5, 7, 9, 11, 13 or 15 will play to the end.

Loop files are with interrupt and may be changed if 1, 3, 5, 7, 9, 11, 13 or 15 are not playing.

There is a brief delay before a new trigger is allowed if a prior triggered file just began.

A trigger on input 9 will cause the file 000 to again be the looping file and all outputs off.

While any of the 8 looping files are playing a corresponding sinking output is active.

Mode 63 is useful to have alternate content looping, such as a menu board with breakfast, lunch and dinner loops, or daily event menus and etc. with the added feature of a motion sensor to trigger an extra file. Retrigger / repeat delay can be set on the motion sensor from a few seconds to over 15 minutes.

Mode 64

Play alternate looping files with alternate paired triggered files, with all interrupts

Mode 64 is the same as Mode 63 except any file playing can be interrupted.

Mode 65

Play alternate looping files with alternate paired triggered files, with delayed trigger

Mode 65 is the same as Mode 63 except the triggered paired file will delay.

A trigger on input 1 or Port 2 will cause the paired file to begin playing, just as the loop ends.

The trigger will delay until the looping file is finished.

Read FAQ about Delayed Trigger at end of manual.

Mode 71

9 inputs + motion (with re-start delay), 8 outputs pulse Low after file ends, no interrupt

Mode 71 controls one Sprite on Port 1.

It has 9 trigger inputs plus an optional motion sensor input on Port 2.

Input 1 and Port 2 have a user selectable delay time to wait before a new trigger.

There are 8 sinking pulsed outputs.

When power is applied the file named 000 will loop circular continuously until a trigger event.

Inputs 1 to 9 will trigger when grounded / connected to input 0

A trigger (ground) on input 1 to 8 will cause the corresponding file named 001 to 008 to play.

Mode 71 is No Interrupt

While a file 1 to 8 is playing, any new trigger on input 1 to 8 or Port 2 will be ignored.

After the file 1 to 8 ends, the corresponding sinking output number will pulse Low for 30ms.

Port 2 is set for a motion sensor input and will trigger on a +3 to +5 Volt input. Plays file 001.

Re-start delay is preset to 30 seconds but may be changed from 1 to 999 seconds.

A push button or other device can be used instead of a motion sensor on Port 2. See page 28.

Mode 71 is used to chain 2 or more Hydras / Sprites together and sequence files.

As an example, you could have 2 or more video "portraits" interacting together.

You could use Port 2 of Hydra 1 with a motion sensor to start file 001.
 Or use Input 1 to start the sequence. It is also using the re-start delay in Mode 71.
 Set the re-start delay long enough for all files in the sequence to play.
 When file 1 ends on Hydra 1, the output 1 can trigger any input on one or more other Hydras.
 Each Hydra output can link to any Hydra input including its own inputs.
 As the file ends on a Hydra it will send a trigger pulse to the next or previous Hydra input(s).
 Long sequences of many files on many Sprites can play in a planned order.
 When any file ends, it can start one or more files on any other Hydra and Sprite.
 One output can be connected to multiple Hydra's inputs to start more than one Sprite.
 A self-sustaining loop can be made to keep playing the pattern over and over.
 On any Sprite, the loop file 000 will be playing anytime file 1 to 8 is not playing.

Mode 72

9 inputs + motion (with re-start delay), 8 outputs pulse Low after file ends, with interrupt

Mode 72 is the same as Mode 71 but with interrupts.
 Any file playing may be interrupted to start a new file when a new input trigger occurs.
 There is a brief delay before a new trigger is allowed if a prior triggered file just began.
 Input 1 and Port 2 still have the re-start delay active.

Mode 73

2 Sprite, 4 inputs each, 8 outs pulse Low after file ends, re-start delay on input 1, no interrupt

Mode 73 controls two Sprites, one on Port 1 and one on Port 2.
 It is similar to Mode 71 but using two Sprite players.
 It has 9 trigger inputs
Input 1 has a user selectable delay time to wait before a new trigger.
 Re-start delay is preset to 30 seconds but may be changed from 1 to 999 seconds.
 There are 8 sinking pulsed outputs.
 When power is applied the file named 000 will loop circular continuously until a trigger event.
 Inputs 1 to 9 will trigger when grounded / connected to input 0.
 Inputs 1 to 4 will play files named 001 to 004 on the Sprite on Port 1.
 Inputs 5 to 8 will play files named 001 to 004 on the Sprite on Port 2.
 Mode 73 is No Interrupt
 While a file 1 to 4 is playing on Port 1, any new trigger on inputs 1 to 8 will be ignored.
 While a file 5 to 8 is playing on Port 2, any new trigger on inputs 1 to 8 will be ignored.
After the file ends, the corresponding sinking output number will pulse Low for 30ms.
 Port 1 files 1 to 4 map to outputs 1 to 4.
 Port 2 files 1 to 4 map to outputs 5 to 8.
 An output can be connected to other Hydra inputs to start files on them.
 Mode 73 is used to sequence files on 2 Sprite players per Hydra.
 As an example, you could have 2 video "portraits" interacting together.
 A self-sustaining loop can be made to keep playing the pattern over and over.

Mode 74**2 Sprite, 4 inputs each, 8 outs pulse Low after file ends, re-start delay on input 1, w/ interrupt**

Mode 74 is the same as Mode 73 but with interrupts.

Any file playing may be interrupted to start a new file when a new input trigger occurs.

There is a brief delay before a new trigger is allowed if a prior triggered file just began.

Input 1 still has the re-start delay active.

Mode 81**1 Sprite, 9 inputs, 8 outputs, files queued, play in the order of inputs triggered, no interrupt**

Mode 81 controls one Sprite on Port 1.

It will store trigger inputs in a queue buffer and play them in the order received.

The first trigger input will play immediately.

It has 9 trigger inputs.

When power is applied the file named 000 will loop circular continuously until a trigger event.

Inputs 1 to 9 will trigger when grounded / connected to input 0.

Inputs 1 to 8 will cause the corresponding file named 001 to 008 to be stored in a queue buffer.

As files are stored, they are played in the order received.

The buffer will only hold 8 triggers.

If an input trigger is already in the buffer, it can't be stored again and will be ignored.

If a file number is currently playing, it can't be stored in the buffer until it has finished.

Mode 21 is No Interrupt

While a file 1 to 8 is playing, it will play to the end.

While the file 1 to 8 is playing, the corresponding sinking output will be active.

Input 9 will interrupt all files, return to the 000 looping file and turn off sinking outputs.

Mode 82**1 Sprite, 9 inputs, 8 output, files queued, play in the order of inputs triggered, delayed trigger**

Mode 82 is exactly the same as Mode 81, except triggers are delayed on file 000.

If file 000 is playing, files stored in the queue buffer will not begin until file 000 ends.

Read FAQ about Delayed Trigger at end of manual.

Mode 81 or 82 could be used for audio announcements where each of the 8 inputs could play a message. Messages will play in the order that the inputs were triggered. Add a second or two of silence to the start and end of each message for best results.

Mode 81 or 82 could be used as an audio or video puzzle, where the user must activate the inputs in a certain order to play the content in the correct order to solve.

Mode 91**DMX input, 1 channel, trigger up to 200 files, safe mode**

Mode 91 controls one Sprite on Port 1 from DMX512 control.

Safe mode only passes the file number to play data to the Sprite.

No control codes are passed.

The Sprite will loop circular the file 000 until it receives a command.

You must set a DMX address from 1 to 512 in the Hydra. See pages 33 to 37.

This is the DMX “channel” that the Hydra will select from the 512 channels received.

This “channel” will contain a single byte of data that your DMX controller sends.

Byte values of 1 – 200 Decimal (01 to C8 Hex) will play files 1 to 200.

A byte value of 255 (FF Hex) will force the Sprite back to the looping file 000.

It is ok if your controller continuously sends the channel data as normal.

The Hydra will ignore repeated data and act on new data values only.

Use a controller that can send a single value “level” command / queue.

A fader will cause the Sprite to try to play every file as the fader moves.

Using a fader may cause unexpected results of video output or freezing.

Mode 92**DMX input, 1 channel, trigger up to 200 files, full mode**

Mode 92 is the same as Mode 91, but will pass all codes to the Sprite

Download the Sprite manual for a list of all possible command codes.

Mode 95**DMX input, 1 channel, trigger up to 200 files, plus DMX control of up to 8 outputs, safe mode**

Mode 95 controls 1 Sprite on Port 1 plus 8 sinking outputs from DMX512 control.

This mode is exactly the same as Mode 91 except it will grab 9 DMX channels.

The DMX address you set in the Hydra is the first channel and is for the Sprite.

The following 8 channels will map to the 8 sinking outputs.

Outputs may be on or off. There is no provision for “dimming”.

Values 0 to 127 (7F Hex) will turn off an output.

Values of 128 (80 Hex) and higher will turn on an output.

It is possible to turn all outputs on at once. Beware of overheating and damage.

The Hydra sinking outputs are intended for small LED lamps or small relays.

Consider using SSR solid state relays to switch higher power loads.

See page 26 for more information about the sinking outputs.

Mode 96**DMX input, 1 channel, trigger up to 200 files, plus DMX control of up to 8 outputs, full mode**

Mode 96 is the same as Mode 95, except it will pass all control codes to the Sprite.

Download the Sprite manual for a list of all possible command codes.

Mode 99

Observe the Hydra firmware revision number

Mode 99 flashes the LED to show the firmware version that is installed in the 9X28D Hydra.

The green LED will flash a number of times with a long pause between.

Firmware version 1 will just flash once with a long pause and repeat.

Version 2 will flash 2 times with a long pause and repeat.

Etc.

Setting Mode by Jumper Wires

There are presently 2 different ways to program the operation Mode:

- 1) Use wire jumpers connected from ground to specified inputs.
- 2) Use the Set push button switch on the front panel.

This section explains method 1, using wire jumpers.

For any method of setting the Mode:

For safety, unplug or remove all Sinking Output wires, if connected. See page 26.

You must hold the Set push button pressed, apply power, and then release the button.

The Hydra will now read the Inputs 1 to 8 and add the values of grounded inputs together.

Use the DMX Port “G” terminal or the Sinking Output Port “C” terminal as the Ground.

Do not connect Input 0.

Input = Value

1 = 1

2 = 2

3 = 4

4 = 8

5 = 16

6 = 32

7 = 64

8 = 128

As an example, if inputs 1, 3 and 5 are connected to the “G” terminal:

The values add up as $1 + 4 + 16 = 21$.

This would run the program Mode 21 from the table on page 4.

See a wiring example on the next page.

The Mode will be saved in memory. The Hydra will start in this Mode every time power is applied, until you decide to set a new Mode.

If you enter a Mode that is not programmed in the Hydra, it will default to Mode 1.

Every time power is applied, the Hydra will flash the yellow LED showing the Mode that is set.

X flashes digit 1 -- Pause -- X flashes digit 2 -- Pause -- X flashes digit 3.

In a DMX Mode: The Mode will flash, then a green flash, then the DMX address will flash.

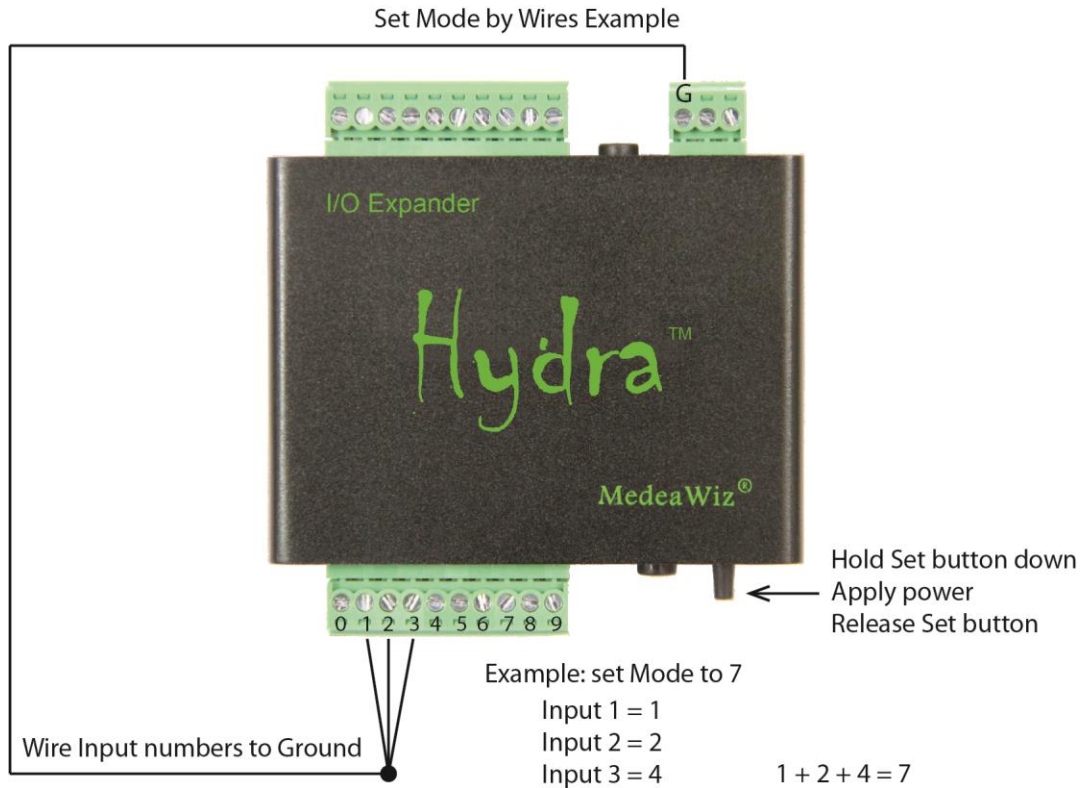

Input = Value

- 1 = 1
- 2 = 2
- 3 = 4
- 4 = 8
- 5 = 16
- 6 = 32
- 7 = 64
- 8 = 128

Setting Mode by Push Button

There are presently 2 different ways to program the operation Mode:

- 1) Use wire jumpers connected from ground to specified inputs.
- 2) Use the Set push button switch on the front panel.

This section explains method 2, using the Set push button.

Forward

Get a cup of coffee. This may take a few minutes to read and understand. You may want to read it two or three times. You can experiment setting the Mode with no worry. If you set it to a wrong or invalid number just try again. If you don't like to read instructions you may want to watch the demonstration video at <https://youtu.be/mz0NgXcQKRE>

You will be able to enter one, two, or three digits by pressing the Set push button.

One digit only for Mode 1 to 9 , or two digits for 10 to 99, or three digits for 100 and up.

Depending on the Mode you want, you may only need to enter one or two digits.

There is a period of time to enter a digit once you start.

Each press will add 1 to the digit value and allow you about 2.5 seconds to make the next press.

If you pause for a few seconds, the yellow LED will flash indicating moving to the next digit.

When entering a digit, press the Set button the number of times required to build the digit.

For example, to enter a "4", press and release the Set button 4 times.

You can press / release it quickly.

Each press / release will cause the LED to go Yellow / Green confirming the entry.

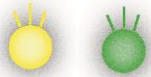

If you just enter one digit and stop, the Hydra will wait about 2.5 seconds, flash the yellow LED, and turn on the green LED for digit two.

If you still do nothing, the Hydra will wait about 2.5 seconds, flash the yellow LED, and turn on the green LED for digit three.

If you still do nothing, the Hydra will wait about 2.5 seconds, both LEDs will be off.

Then the green LED will flicker to indicate your Mode is stored in memory.

Next the Hydra will "play back" your digit presses by flashing the yellow LED.

Count the flashes for each digit, with a pause between digits, to verify your entry.

If you need to enter a zero, there are 2 ways:

- 1) Press the Set button 10 times.

OR

- 2) Hold the Set button until the LED flashes, indicating moving to the next digit.

For any method of setting the Mode, you must hold the Set push button pressed, apply power, and then release the button.

Example for single digit Mode 2

Unplug / turn off the power to the Hydra.

Remove all input wires. You can pull out the plug to disconnect them.

If any input is grounded, the Hydra will read the inputs and ignore your Set button.

Hold the Set button pressed down and turn on the power.

The yellow LED will light



Release the Set button

The Green LED will light indicating ready. You must start entry / press before 2.5 seconds.



Press and release the Set button 2 times for Digit One.

Each press / release will cause the LED to go Yellow / Green



Yellow indicates the button is down, Green that the button is up and ready to press.

After entering your Digit One:

Wait 2.5 seconds and see the Yellow LED flash on, then back to Green

The Hydra is now ready for you to enter the Digit Two (You will do nothing).

Wait another 2.5 seconds and see the Yellow LED flash on, then back to Green

The Hydra is now ready for you to enter the Digit Three (You will do nothing)

After 2.5 seconds both LEDs are dark

Then the Green LED will flicker to indicate your Mode is stored in memory.



Now the Hydra will flash the yellow LED to show the count you entered.

Two yellow flashes for Digit One

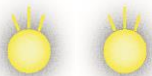

Last, the Green LED will remain on. Green for all input Modes, or Yellow for any DMX mode.



Example for two digits Mode 15

Unplug / turn off the power to the Hydra.

Remove all input wires. You can pull out the plug to disconnect them.

If any input is grounded, the Hydra will read the inputs and ignore your SET button.

Hold the Set button pressed down and turn on the power.

The yellow LED will light



Release the Set button

The Green LED will light indicating ready. You must start entry / press before 2.5 seconds.



Press and release the Set button 1 time for Digit One.

Each press / release will cause the LED to go Yellow / Green



Yellow indicates the button is down, Green that the button is up and ready to press.

After entering your Digit One:

Wait about 2.5 seconds and see the Yellow LED flash on, then back to Green

The Hydra is now ready for you to enter the Digit Two.

Press and release the Set button 5 times for Digit Two.

Each press / release will cause the LED to go Yellow / Green



After entering your Digit Two:

Wait about 2.5 seconds and see the Yellow LED flash on, then back to Green

The Hydra is now ready for you to enter the Digit Three (You will do nothing)

After 2.5 seconds both LEDs are dark

Then the Green LED will flicker to indicate that your Mode is stored in memory.



Now the Hydra will flash the yellow LED to show the count you entered for each digit.

Digit One



Brief pause then

Digit Two



Last, the Green LED will remain on. Green for all trigger input Modes, or Yellow for any DMX mode.



The Mode will be saved in memory. The Hydra will start in this Mode every time power is applied, until you decide to set a new Mode.

If you enter a Mode that is not programmed in the Hydra, it will default to Mode 1.

Every time power is applied, the Hydra will flash the yellow LED showing the Mode that is set.
X flashes digit 1 -- Pause -- X flashes digit 2 -- Pause -- X flashes digit 3.

In a DMX Mode: The Mode will flash, then a green flash, then the DMX address will flash.

Wiring a Pushbutton to the Input Port

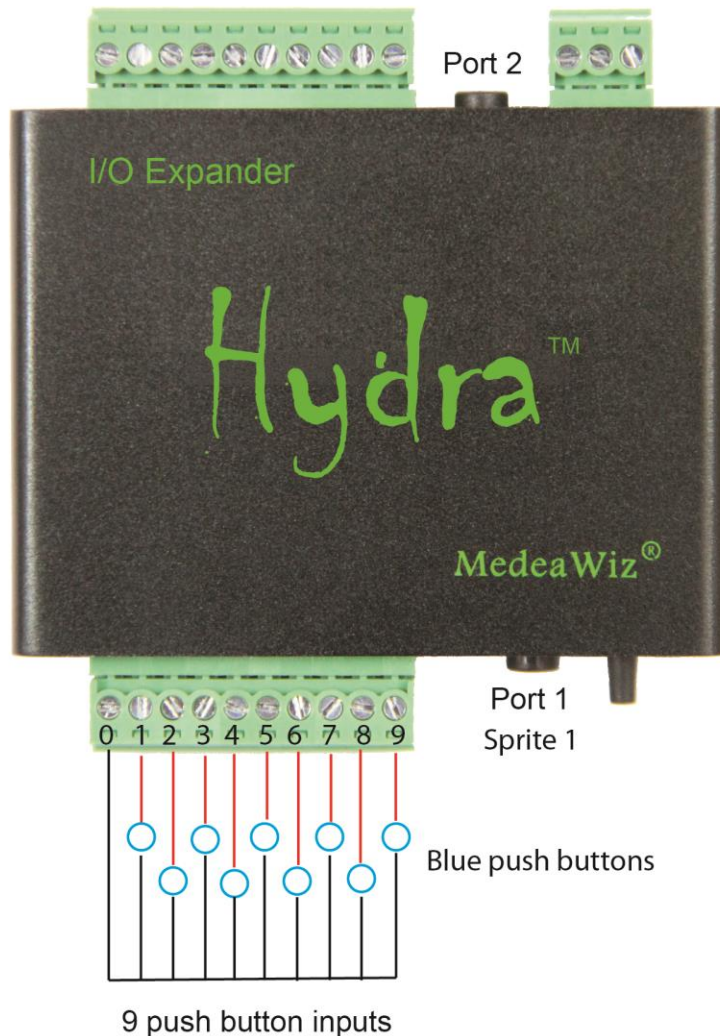

Each pushbutton should have 2 terminal connections.
Connect either terminal to the "0" terminal on the Hydra.
Connect the other unused terminal to the input number.
If you have a 3 terminal micro-switch button, use the "C" and the "NO" terminals.
Plug the Sprite into Port 1.
Set the Sprite to Serial Control at 9600 Baud. Do Not use Addressing.

Depending on the Mode set in the Hydra, a second Sprite or motion sensor may be plugged into Port 2.

Wiring Connections to the Output Port

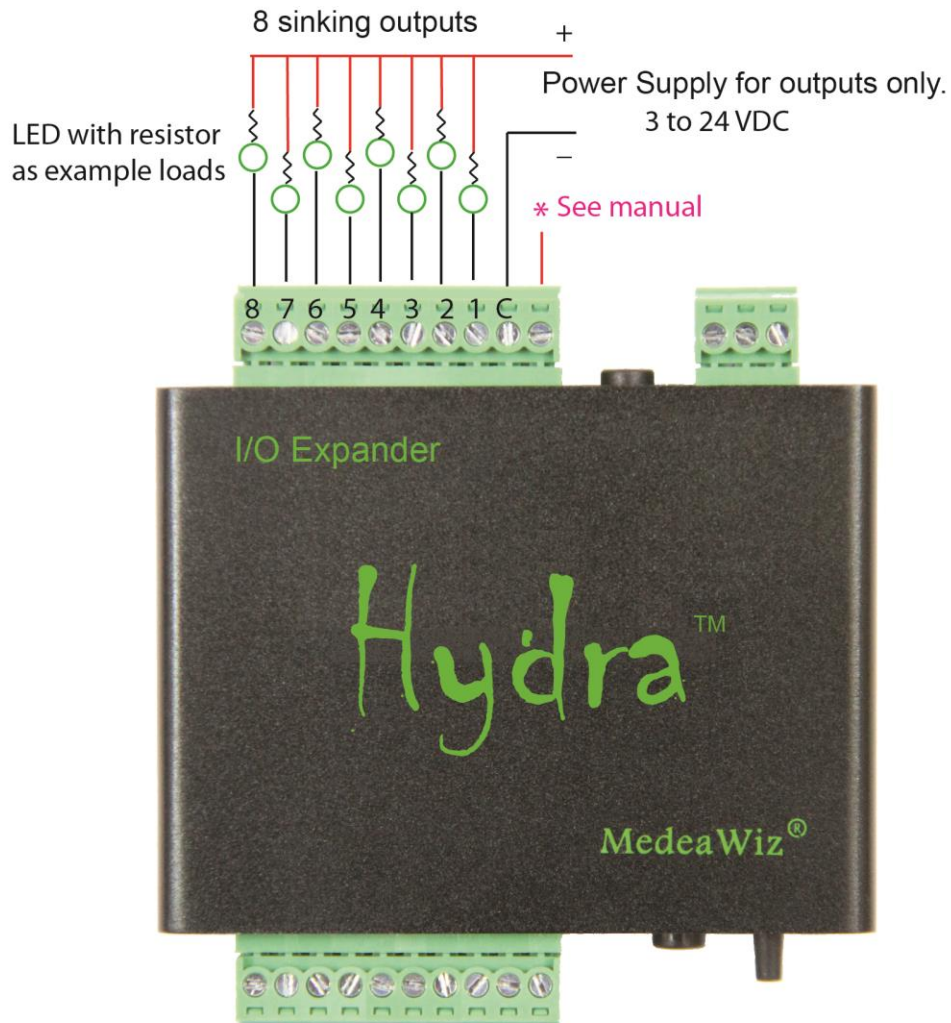

The Hydra has “sinking outputs”, which means that it switches the Ground or “Minus” side of the power supply. In this case you will connect the Positive “Plus” of your external power supply directly to all output devices. The Negative “Minus” side of each output device will connect to one of the output numbers 1 through 8 on the Hydra.

***If you are using inductive loads**, such as a relay coil or small solenoid coil, you must also connect your external power supply Positive “Plus” to the + terminal for “back EMF” protection. Alternately you may supply external clamping diodes at the coil. Lamps, LEDs and SSR solid state relays do not require this + connection to the Hydra.

Each output is rated for up to 150mA at up to 28 Volts DC, one output active.

Details on Outputs

NOTICE:

Use Caution when any output of the hydra is used to control any device that could cause harm. While not likely, remember that it is possible that an output will activate unexpectedly. Do not use with any device that could cause harm to person or property. We advise that you unplug the output terminals when changing Mode or re-programming.

The Hydra sinking outputs are intended for small LED lamps or small relays. Consider using SSR solid state relays to switch higher power, voltage or AC loads. An SSR relay typically only needs around 20mA to operate.

Each output is rated for up to 150mA continuous at up to 28 Volts DC, one output active. Each output of the Hydra has a 2Ω .063W resistor “fuse” in the line to protect the TBD62083. The 2 Ohm resistor will begin to heat above 175mA, acting as a fuse to protect the Hydra.

If all 8 outputs are active you should limit the loads to 400mA or less total, 150mA max on any single output.

For multiple outputs active and complete specifications you should refer the Toshiba TBD62083 data sheet here:

<https://toshiba.semicon-storage.com/us/product/linear/transistor-array/detail.TBD62083AFWG.html>

The circuit board has a place to solder a fuse or diode that will allow the Hydra to supply 5 Volts DC for your load devices. This may be suitable for LED lamps or SSR solid state relays. Keep in mind the 5V power comes from the Sprite. We will not warranty the Hydra or the Sprite if improper voltage is applied.

We will not warranty any Hydra with damaged output drivers. Please use caution when selecting load devices, power supply and wiring.

Wiring Connections to Port 2

In a Mode where a second Sprite® is used on Port 2

Use the standard 3.5mm 4 pole serial cable to connect a second Sprite to Port 2.

In a Mode where a sensor or other trigger is used on Port 2

This Port is “pulled” Low internally and requires a positive 3 to 5 Volts to trigger. The PIR motion sensors we provide can plug directly into the port.

You may use a push button on Port 2. Connect the push button to the “L” and “R” terminals of the screw terminal adaptor. The adaptors are provided with the Sprite media player.

In Modes that use the re-trigger delay on Port 2, a jumper wire may be installed to force the file to start playing at regular intervals. The time can be set from 1 to 999 seconds.

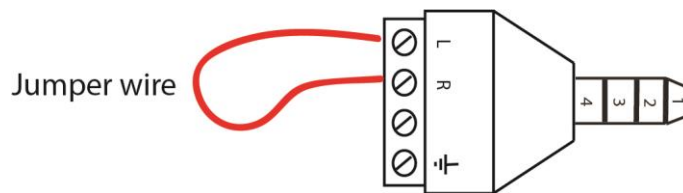

Port 2 Motion Sensor Wiring

In some Modes, a motion sensor may be used on Port 2

There are small PIR motion sensors available that use 5 Volt power and have a TTL voltage output. These can be powered directly from the 9X28D Hydra Port 2.

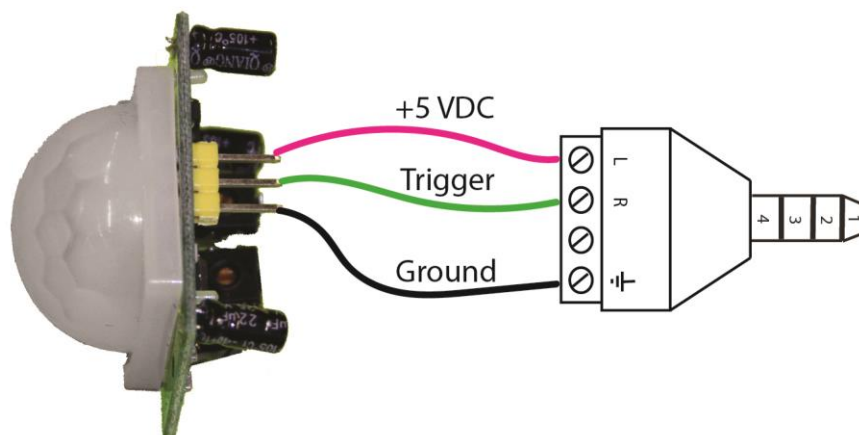

Setting Re-Trigger Delay

The re-trigger delay is factory set to 30 seconds but may be changed from 1 to 999* seconds.

The delay is for the Port 2 input, primarily for using a motion sensor.
The delay does not affect inputs 1 to 9 in *most* Modes.

The delay uses the DMX address value.

Enter a DMX address / Delay value equal to your desired time delay in seconds.
Please refer to Setting the DMX Address on pages 33 to 37.

The re-trigger delay on Port 2 can be used in various ways.
In a kiosk or special effect, you may want some quiet time between motion triggers.
You can also connect a jumper wire to force a trigger at intervals set by the delay time.

*Notes on delay time:

Short delay times under 5 seconds may have unpredictable trigger results.

Delay times are not exact due to variations in components.

Delay times can change slightly at different ambient temperature extremes.

The value you enter is the number of desired seconds of delay.

The maximum setting of 999 will be approximately 16 minutes and 39 seconds.

The delay may activate when power is applied. The first trigger may be after your delay time.

Matrix and Keypad Button Wiring

Matrix wiring of the inputs allows us to use many more pushbuttons than the individual inputs available.

We use a system of Columns and Rows. Each column and each row is assigned to an input on the Hydra.

A pushbutton will have 2 terminals. One is connected to a column and the other to a row.

Each intersection of a column and row is a place for a pushbutton. See the example on page 32.

Since the Hydra has 10 input terminals, we can have up to a 5x5 matrix with up to 25 push buttons.

3x4 Matrix wiring Input terminals marked on the front panel

Button number	Input Connection 1	Input Connection 2	Plays file named
1	0	3	001
2	1	3	002
3	2	3	003
4	0	4	004
5	1	4	005
6	2	4	006
7	0	5	007
8	1	5	008
9	2	5	009
10	0	6	010 (* clear key on Mode 33, 34)
11	1	6	011 (zero on Mode 33, 34)
12	2	6	012 (# enter key Mode 33, 34)

4x4 Matrix wiring Input terminals marked on the front panel (bug in version 3 – do not use)

Button number	Input Connection 1	Input Connection 2	Plays file named
1	0	4	001
2	0	5	002
3	0	6	003
4	0	7	004
5	1	4	005
6	1	5	006
7	1	6	007
8	1	7	008
9	2	4	009
10	2	5	010
11	2	6	011
12	2	7	012
13	3	4	013
14	3	5	014
15	3	6	015
16	3	7	016

5x5 Matrix wiring Input terminals marked on the front panel

Button number	Input Connection 1	Input Connection 2	Plays file named
1	0	5	001
2	0	6	002
3	0	7	003
4	0	8	004
5	0	9	005
6	1	5	006
7	1	6	007
8	1	7	008
9	1	8	009
10	1	9	010
11	2	5	011
12	2	6	012
13	2	7	013
14	2	8	014
15	2	9	015
16	3	5	016
17	3	6	017
18	3	7	018
19	3	8	019
20	3	9	020
21	4	5	021
22	4	6	022
23	4	7	023
24	4	8	024
25	4	9	025

Wiring for 3x4 matrix keypad or up to 12 individual push buttons.

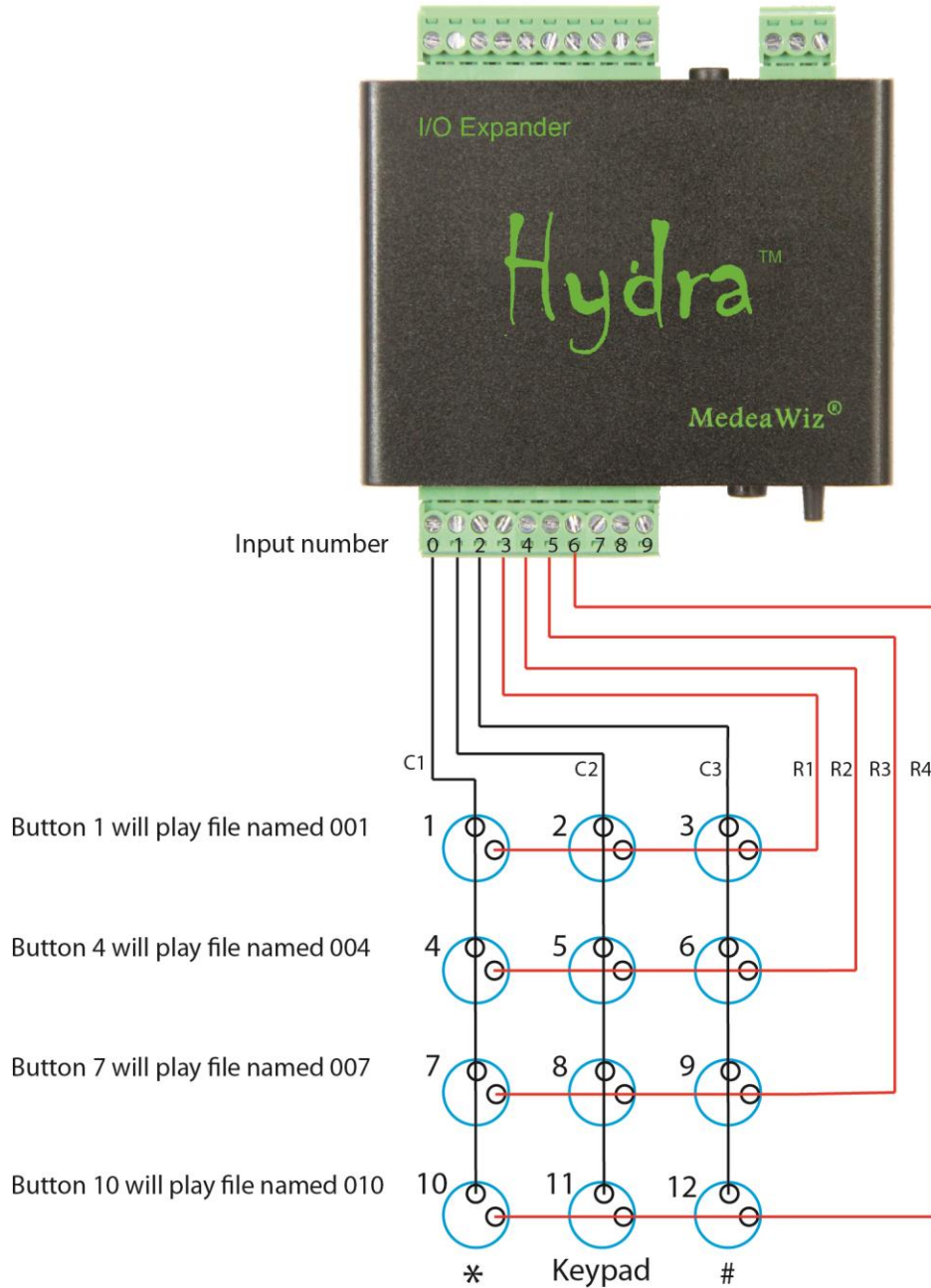

Keypads vary by manufacturer. The Columns and Rows may be in a different order than shown.

A 4x4 keypad wiring will be similar but using inputs 0-3 as C1-C4 and inputs 4-7 as R1-R4.

A 5x5 push button arrangement will use inputs 0-4 as C1-C5 and inputs 5-9 as R1-R5.

DMX Control

DMX512 (Digital Multiplex) is a standard for digital communication networks that are used to control stage lighting and effects. Learn more at Wikipedia:

<https://en.wikipedia.org/wiki/DMX512>

Multiple lights, special effects, props and Sprites may be connected to a single pair of wires and individually controlled from a DMX console or computer with a USB to DMX adaptor.

DMX512 use has grown into other areas including theme parks, haunted houses, Christmas shows, escape rooms, museums, trade shows, and more. With DMX512 you can have a master control device programmed to run a complete scripted automated show that includes all types of lighting, special effects, mechanical / pneumatic movements, and audio / video. Many third-party controller options are available including software programs to run on a PC. They will allow you to construct a full show from a series of events at specific times.

The Hydra allows you to play audio / video files from the MedeaWiz Sprite using your DMX512 controller. Multiple Sprite media players can be controlled independently from a single cable.

Sending commands to the Hydra for the Sprite

You will need to set an address in the Hydra to match the DMX512 channel you will use. Your DMX controller will transmit 1 byte of data on this channel to the Hydra repeatedly. The Hydra will select the DMX byte at the address and pass it to the Sprite media player. Only new / different data bytes get passed to the Sprite. Repeated ones are discarded. We discuss the serial codes in two categories: Playing files and other commands. Each DMX program in the Hydra has a “safe mode” and a “full mode”

DMX safe mode

With “safe mode” there is no risk of accidentally changing a setting in the Sprite. It will only pass data to the Sprite to play files from 001 to 200, and return to file 000. Hex 0x01 to 0xC8 will play files named 001 up to 200. Since DMX controllers transmit 00 normally for lights off, we use 0xFF to play file 000. Please refer to the Sprite manual online for a list of all serial control codes.

DMX full mode

The “full mode” will pass all byte data. In the Sprite, values above 0xC8 are used for various transport controls such as pause and play, volume control, mute, video and audio output settings and more. Accidentally sending one of these commands could stop your show and require a reset. It may be necessary to use the IR remote control with the Sprite to enter the setup menu to restore. The Hydra will ignore repeated commands. To send repeat commands, such as for Next file, you should send an unused command such as 0xFE before resending the same command.

Wiring Connections to the DMX Port

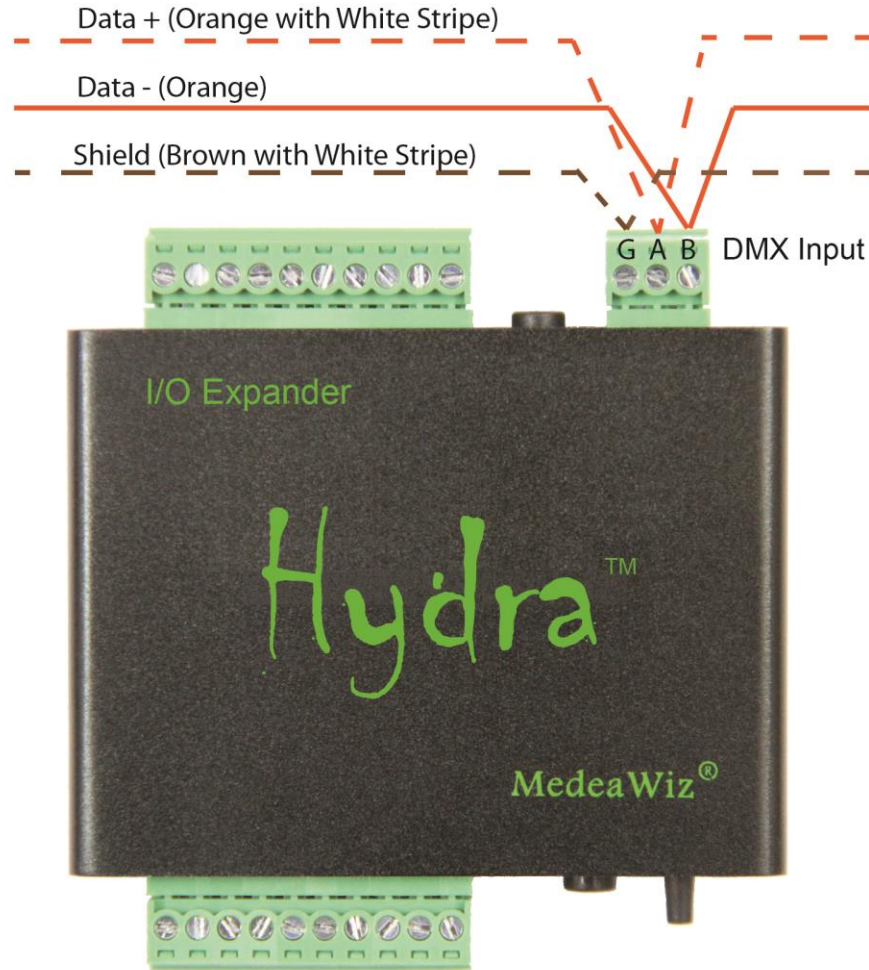

The DMX Port should only be connected to a DMX 485 bus device. Standard A, B and Ground / Shield terminals are provided. Commonly used colors are shown for Cat 5 cable above. Your colors may vary. DMX wiring for XLR and RJ45 connectors are shown below.

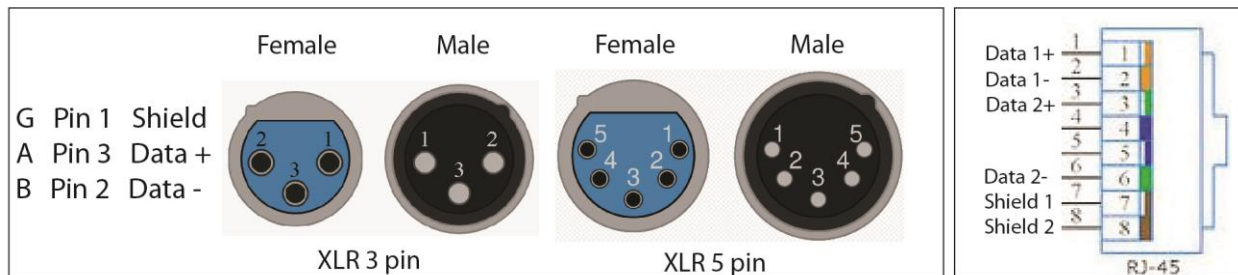

Setting DMX Address by Jumper Wires

A new Hydra has DMX address 32 set as default.

There are presently 2 different ways to program the DMX Address:

- 1) Use wire jumpers connected from ground to specified inputs.
- 2) Use 1 jumper wire and the Set push button switch on the front panel.

This section explains method 1, using wire jumpers.

Connect input 0 to terminal “G” on the DMX port.

If any input 1 – 9 is grounded, the Hydra will add the values of the inputs for the DMX address. If no inputs are grounded, the Hydra allows you to enter the address by the Set push button.

Each input 1 through 9 has a value as follows:

1 = 1

2 = 2

3 = 4

4 = 8

5 = 16

6 = 32

7 = 64

8 = 128

9 = 256

Select all inputs needed to add up to the DMX address you desire.
Ground these inputs to the DMX terminal G.

For any method of setting the DMX Address, you must hold the Set push button pressed, apply power, and then release the button.

As an example, if inputs 1, 6 and 8 are grounded:

The values add up as $1 + 32 + 128 = 161$.

The Hydra will pass serial commands received on DMX address 161 out to the Sprite.

See wiring and an example on the next page.

The DMX address will be saved in memory. The Hydra will start in DMX Mode at this address every time power is applied, until you set a new Mode or DMX address.

The Hydra will flash the Yellow LED to indicate the address. Digit 1, pause, Digit 2, pause, Digit 3

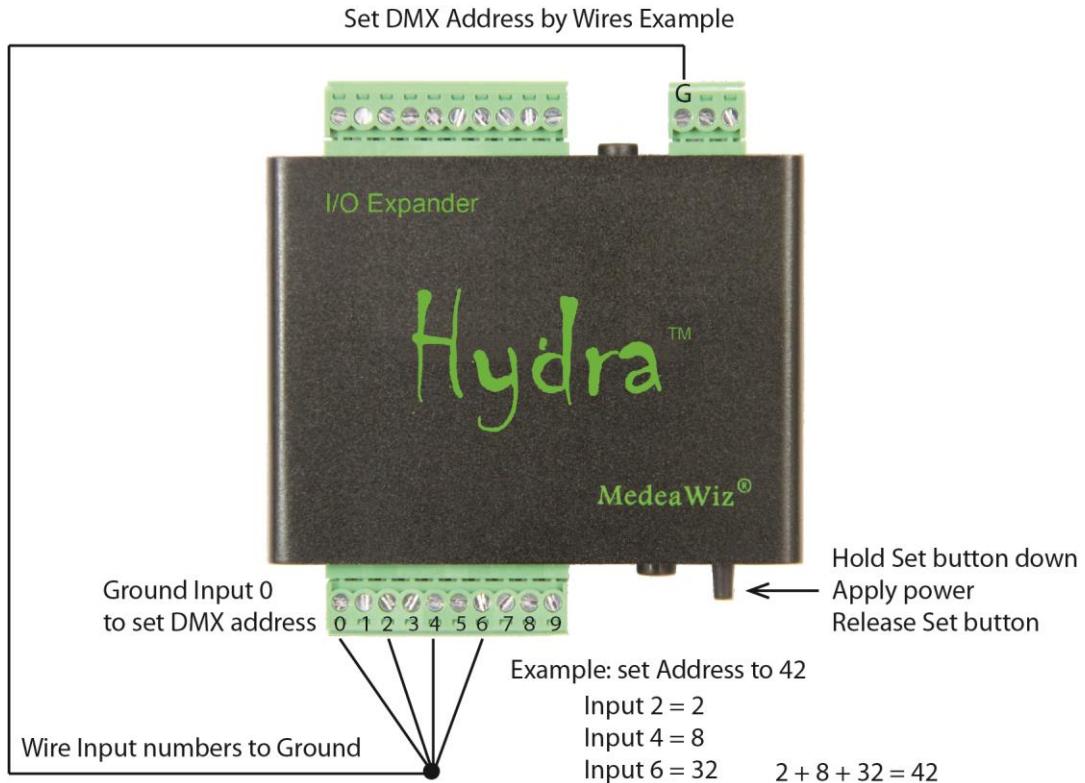

Input 0 must be grounded to let the Hydra know you want to set the DMX address . Values of any Inputs 1 – 9 that are grounded will add together to make the address.

The Hydra will confirm your entry by flashing the yellow LED. For our example Address 42:

Digit 1  PAUSE Digit 2 

Each input 1 through 9 has a value as follows:

- 1 = 1
- 2 = 2
- 3 = 4
- 4 = 8
- 5 = 16
- 6 = 32
- 7 = 64
- 8 = 128
- 9 = 256

Setting DMX Mode and Address by the Set Push Button

A new Hydra has DMX address 32 set as default.

This section explains method 2, using the Set push button to set the DMX address.

Connect input 0 to terminal “G” on the DMX port.
Make sure no other inputs 1 – 9 are connected.

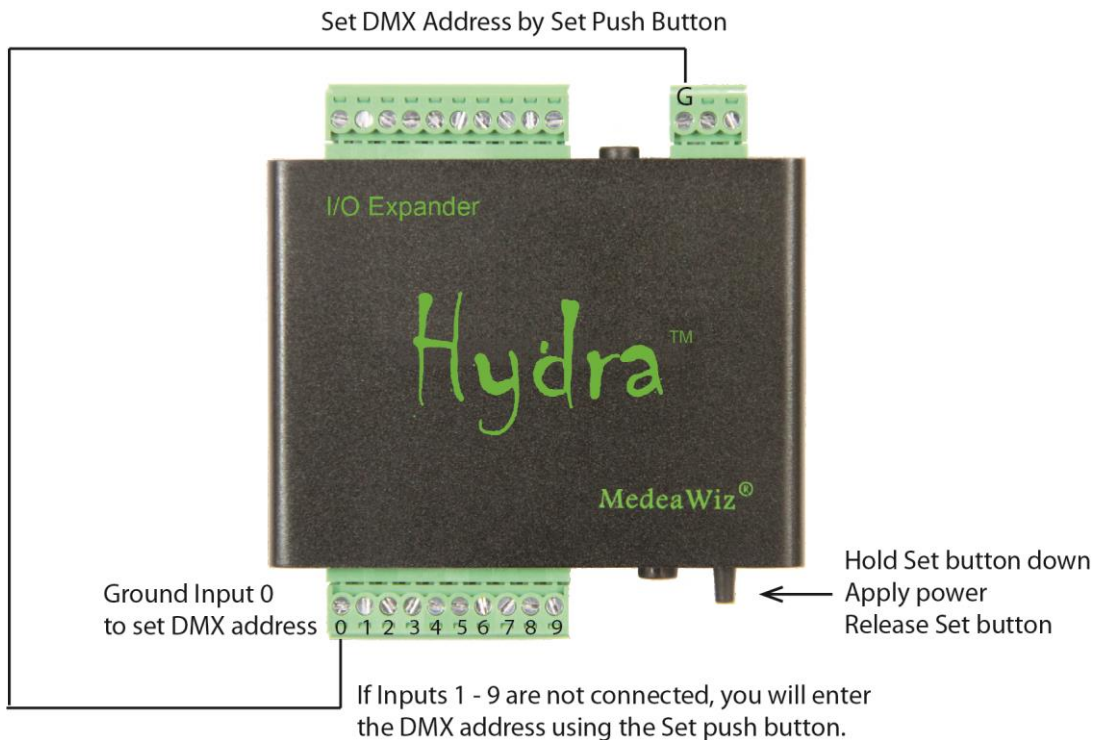

Please refer to Setting Mode by Push Button on page 21.

The procedure to set the DMX address by push button is the same.

Remember to enter a zero, you can press the MODE button 10 times, or hold it down until the LED flashes.

After you set the DMX address the Hydra will flash the yellow LED in a sequence to confirm the address:

x flashes Digit 1, pause, x flashes Digit 2, pause, x flashes Digit 3

See the video demonstration at <https://youtu.be/mz0NgXcQKRE>

Restore Default Settings

To set the Hydra back to the factory default Mode 1

Remove all wires from the inputs 1 – 9.

Then connect a jumper wire from Input 1 to the DMX terminal “G” on the rear panel.

Hold the Set push button pressed while applying power to the Hydra.

After power is applied, release the button.

This change will not reset the re-trigger delay or the DMX address.

Firmware Upgrade / User Programming

We may release upgraded firmware in the future. Please check <http://www.medeawiz.com/> or follow the MedeaWiz Sprite on Facebook <https://www.facebook.com/MedeaWiz/> for updates.

Distributors may offer a service to upgrade your firmware for a small fee plus shipping.

PLC Interfacing

The Hydra™ can be controlled from a Programmable Logic Controller using “dry contacts” like a push button, or voltage output.

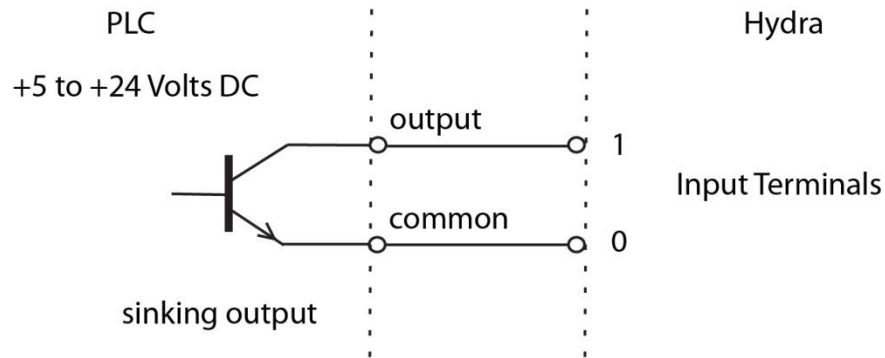

The sinking output above is the preferred method if dry contacts are not available.

For some devices / sensors, it will be better to use the DMX Port “G” terminal, or the Sinking Output “C” terminal as the Common / Ground, instead of using the “0” terminal. The “G” and “C” terminals are grounded internally to the power Ground. The “0” terminal has a series input resistor and a weak pull-up resistor as shown on the next page.

The Hydra has an internal weak pull-up 47K resistor.

Do not share PLC outputs with relays, motors or solenoids /valves. These devices can produce voltage spikes. Keep them on separate isolated outputs away from the Hydra inputs.

Schematics of I/O on the 9X28D Hydra™ circuit board

Hydra Input Terminals 0 through 9

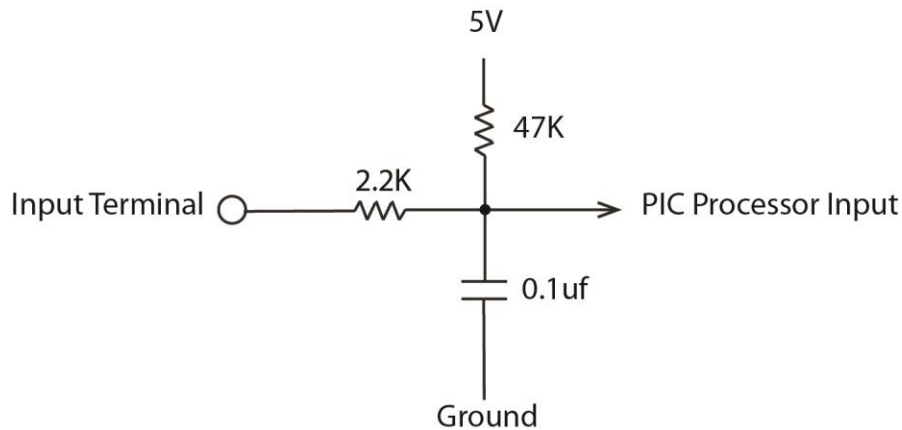

The Hydra input terminals 0 through 9 have a 2.2K series resistor to help limit current flow to a safe level for the PIC processor. There is a 47K pull-up resistor to bias the inputs to a High state. There is a 0.1uf capacitor to help reduce stray noise.

Hydra Port 1 Input

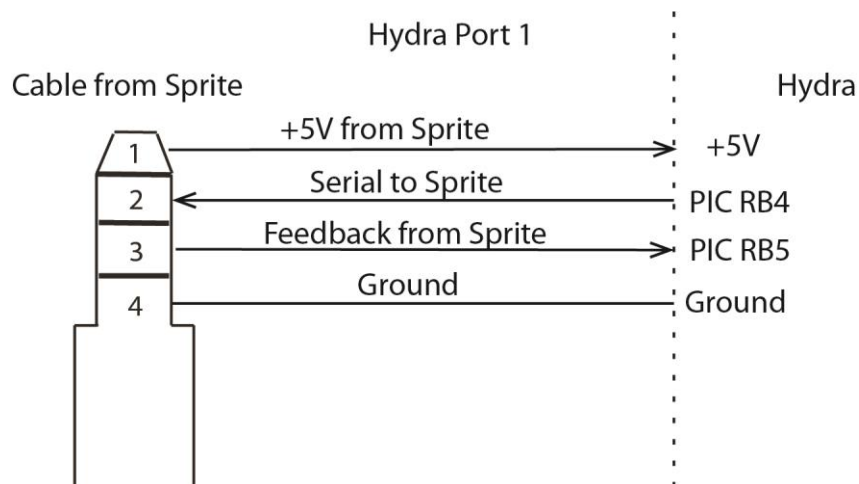

The Sprite media player connects to Port 1 of the Hydra. The Sprite will supply the 5 Volt power to the Hydra. The serial communications TX and RX are direct to the PIC processor on this port.

Hydra Port 2 Input

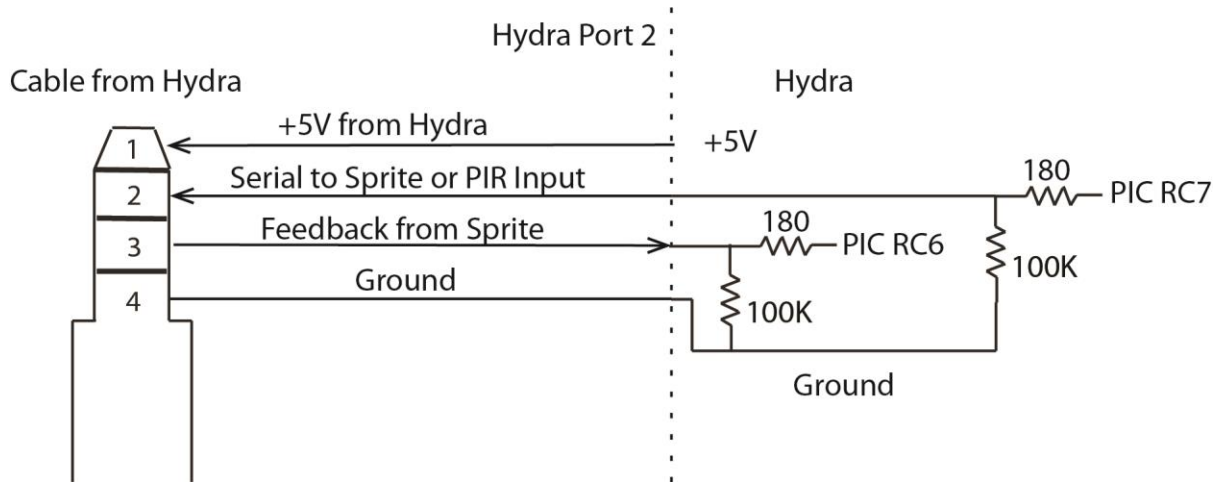

The Hydra Port 2 can be used for a second Sprite or as an input for a motion sensor or other trigger. The use depends on the operation Mode that you select from the table on page 4.

Port 2 has 100K weak pull-down resistors and will trigger on a +3 to +5 Volt input.

The Hydra will supply +5V power on Port 2 for a second Sprite or a motion sensor. A Sprite should be connected to Port 1 to supply power to the Hydra and Port 2.

Do not connect a power supply to a Sprite on Port 2.

Hydra DMX Port

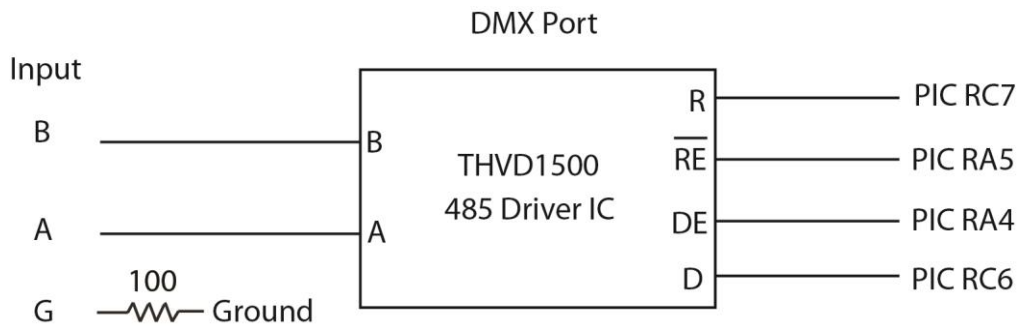

The DMX port is not isolated. Minimal transient suppression is provided internally by the THVD1500. This type of DMX receiver circuit will work fine for most applications. However some installations with mixed equipment and / or long wire runs may generate voltages that may damage the Hydra.

The Hydra PIC processor shares pins RC6 and RC7 with the DMX Port and Port 2. In a DMX Mode, a 485 bus serial byte will be output on Port 2 for a 485 to TTL conversion.

Hydra Sinking Output Port

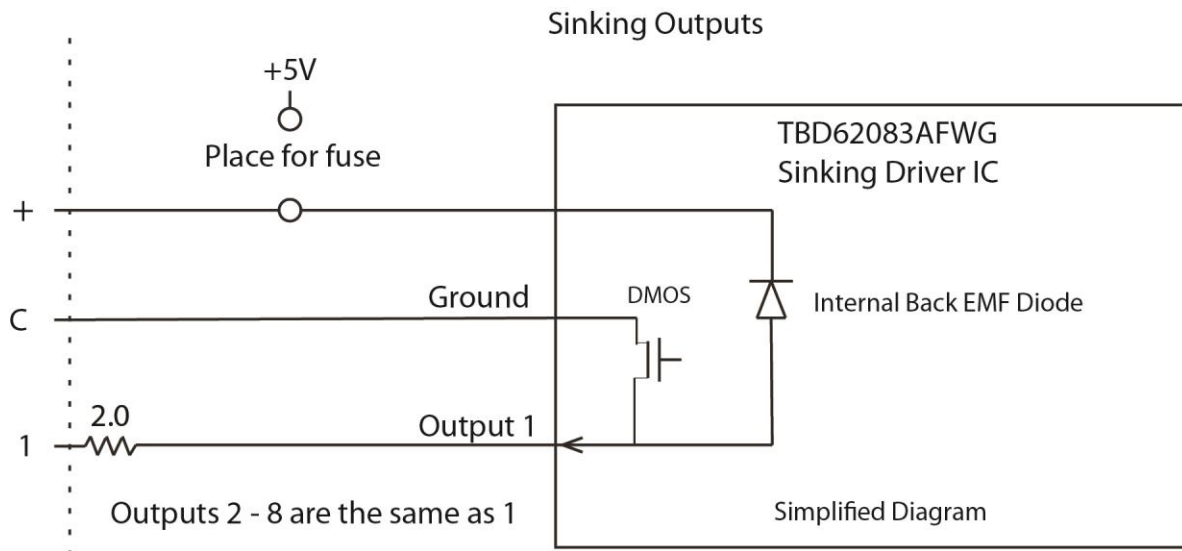

When an output is turned on, the “C” terminal is connected internally to the output terminal and provides the Ground for your external equipment.

The Hydra has “sinking outputs”, which means that it switches the Ground or “Minus” side of the power supply.

In this case you will connect the Positive “Plus” of your external power supply directly to all output devices.

The Negative “Minus” side of your external power supply will connect to the “C” terminal on the Hydra.

The Negative “Minus” side of each output device will connect to one of the output numbers 1 through 8 on the Hydra.

***If you are using inductive loads**, such as a relay coil or small solenoid coil, you must also connect your external power supply Positive “Plus” to this terminal for back EMF protection. Alternately you may supply external clamping diodes at the coil. Lamps, LEDs and SSR solid state relays do not require this connection.

Each output is rated for up to 150mA continuous at up to 28 Volts DC, one output active. The 2 Ohm resistor will begin to heat above 175mA, acting as a fuse to protect the Hydra. Refer to the Toshiba TBD62083 manual for more technical specifications information.

A wiring example for LED lamps is on page 26.

Technical Details

The 9X28D Hydra uses a Microchip® brand PIC18F45K42 processor and is programmed in C language.

If you are familiar with programming and loading these processors we can provide you with the latest image.

You may re-program the Hydra using your own custom program. We suggest that you mark the Hydra in some way to show that it is a custom program. This will help if someone needs technical assistance later.

If you want to load a program we provide into the Hydra or if you want to program it yourself, you will need to download free software from <https://www.microchip.com/> and purchase a tool such as the PICkit 3 to connect your PC or laptop to the Hydra.

Free MPLAB software <https://www.microchip.com/mplab/mplab-x-ide>

Trouble FAQ

The LED power light is not on:

The Hydra gets power from a Sprite plugged into Port 1. Make sure the Sprite power LED is on and that the Sprite is plugged in to the Hydra with the 4 pole, 4 wire 3.5mm cable supplied with the Hydra.

I am having trouble setting the operation Mode or DMX address:

See the video demonstration at <https://youtu.be/mz0NgXcQKRE>

About the Delayed Trigger modes:

The delayed trigger modes will hold the trigger event until the Sprite reaches the end of the 000 looping file. On occasion, the Sprite may start and show a few frames of the 000 looping file before starting the newly triggered file. If your video files have a few frames of black at the beginning, OR if all file beginning frames are the same image on each file, this should not be noticed.

My video has a glitch or green area when looping or triggered

This often happens if your video bit rate is too low. We suggest a bit rate of 20,000Kbps (20Mbps) or higher. Do not compress the files. Let the bit rate be high at the normal setting.

The file's pixel size should be 1920 x 1080 for the 1080p or 1080i settings, and 1280 x 720 for the 720 settings. It is helpful to have all of the files made in the same format and encoding.

You can also try another Video Output Mode setting, 720p 50, 720p 60, 1080p 24 and etc., in the Setup Menu. Often this will solve the issue without altering your files.

You may need to alter your files with video editing software. These settings work well:

- CODEC = H.264
- Pixel size = 1920 x 1080
- Frame rate = 60 fps
- Bit rate = 20,000Kbps (20Mbps)
- Set the Sprite® Video Output Mode to 1080p_60HZ

There are numerous video editing software programs available. We use Power Director from www.cyberlink.com It does a good job and is not expensive.

Firmware Revisions

Firmware version 2

Fixed a problem where Modes 11 through 17 did not acquire the number of files on disc unless the Sprite was booted and running first. Added some delay before requesting the number of files on the disc to allow the Sprite to boot.

Firmware version 3

Fixed a problem where Modes 41 and 42 played wrong file numbers using input 3.

There may be some bugs in the 3 x 4 matrix modes in some V3 Hydras.
Please use a 4 x 4 or 5 x 5 matrix mode with fewer buttons or contact support.

Support

We do our very best to answer your calls and emails in a timely manner. We generally return calls and emails within 2 hours or less during business hours. We do monitor emails in the evenings and weekends and will try to respond outside of business hours.

Please read the entire manual. If we have a good manual then we will get fewer calls. Let us know where we can improve it to help others in the future.

If you are still having trouble, or need technical support for some other application, please email or call us. We are here to help when you need it.

World-wide

support@MedeaWiz.com

In USA

Team Kingsley LLC

support@TeamKingsley.com

618-797-9951 x300

Custom Orders

We offer custom programming for the H-9X28D Hydra™ in any quantity. Contact us with details for a quote.

Please email sales@MedeaWiz.com for a quote.